



since 1996

大正咖啡集团  
DAZHENG COFFEE GROUP

# Myth Semi-automatic Espresso Machine Product Introduction

✉ [sales@coffeedazheng.com](mailto:sales@coffeedazheng.com)

☎ +86 18011762132

🌐 [www.coffeedazheng.com](http://www.coffeedazheng.com)

# Legend Evolution Forging Myth

## Myth Semi-automatic Espresso Machine

The core of design inspiration is the vibrant image of the annual rings. We integrate its essence into every detail of the machine: cool screen operation of technology, Using metal etching process to simulate annual ring vision, all seem to be talking about the sedimentation and accumulation of time. annual rings extend infinitely from the core outward, symbolizing our endless exploration of the essence of coffee.

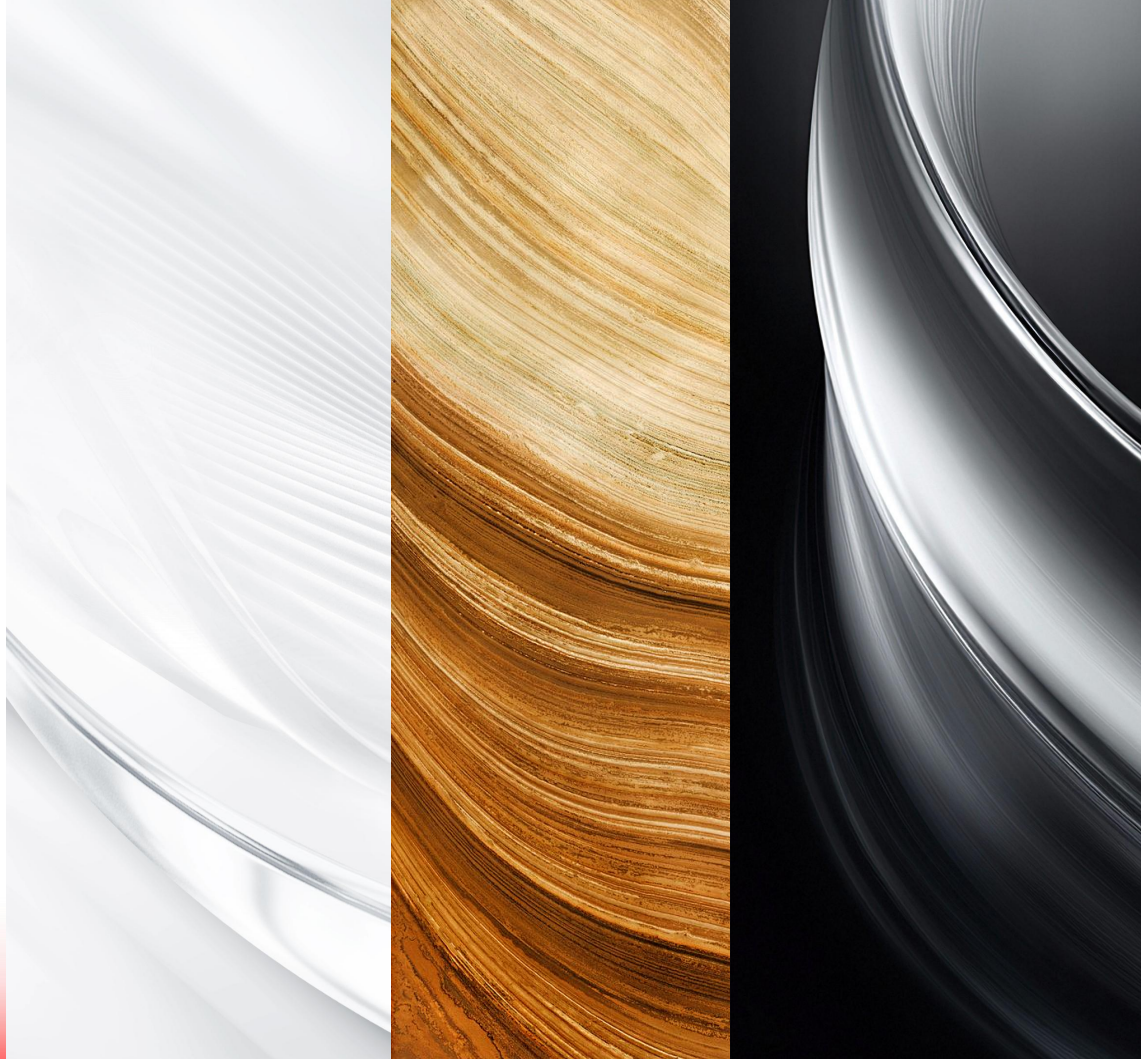

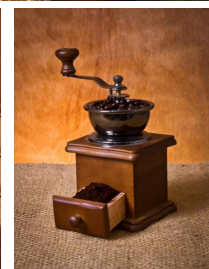
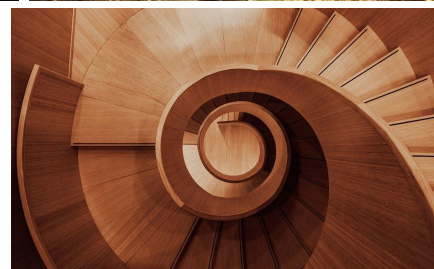
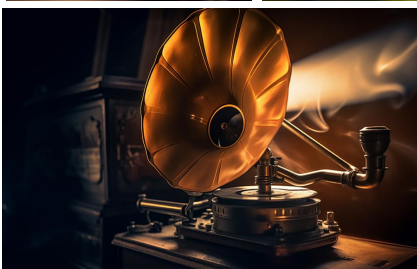

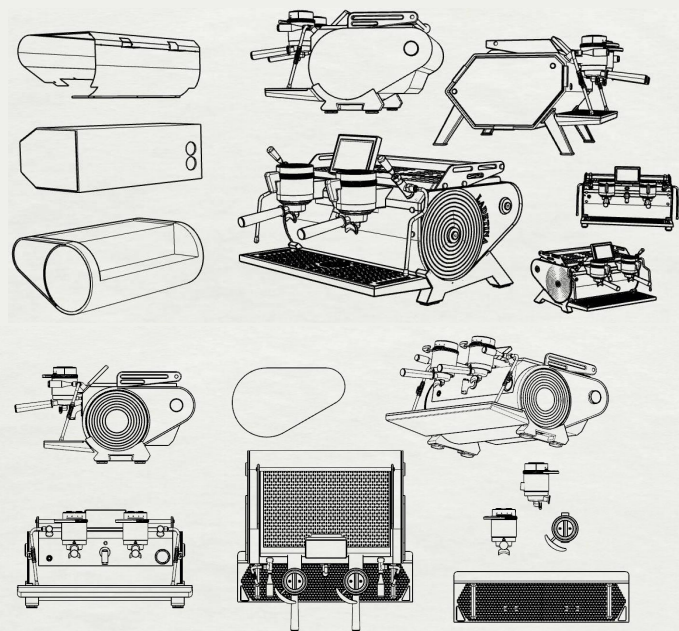
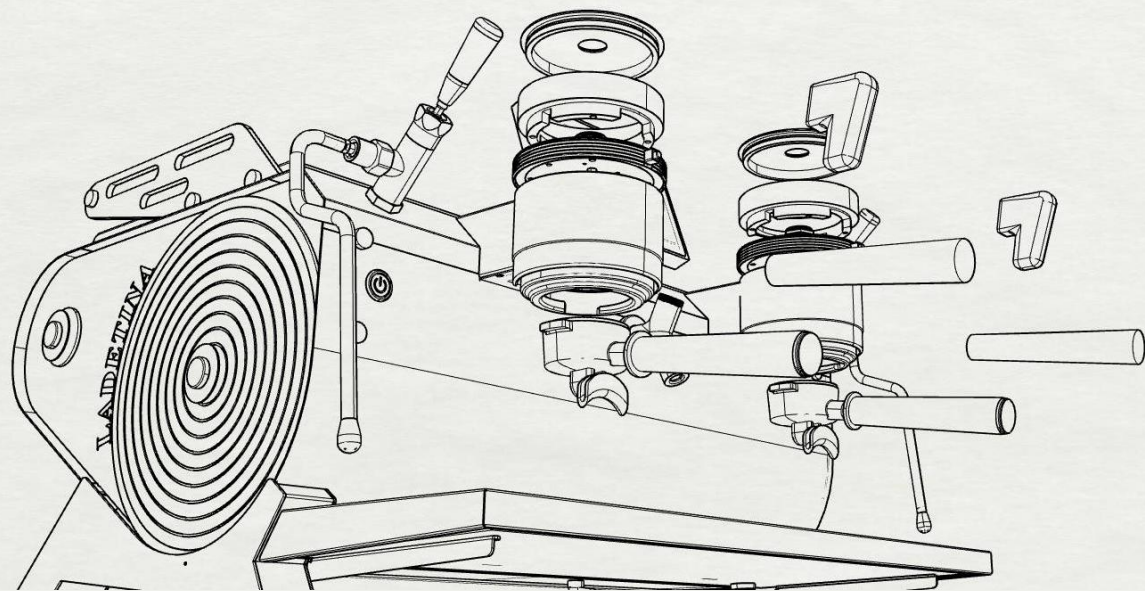



# Myth Semi-automatic Espresso Machine

## Legend Evolution - Forging Myth

PID Temperature  
control technology

7.0 Inches  
Touch Screen

Saturated  
Group head



Front View



Left 45° Viewing



Rear View

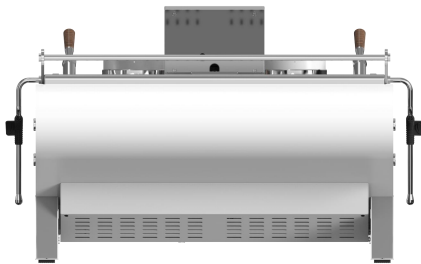

Side View

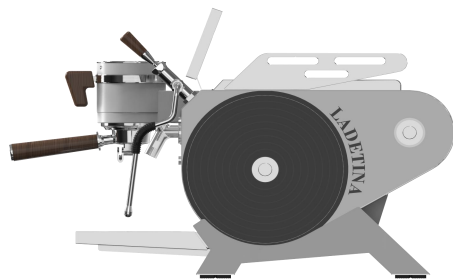

# “products Basic parameters

**Model : AT2-2**

**Boiler  
Capacity : 7L**

**Color : White/Black**

**Saturated  
Group Head : 1.2L\*2  
Capacity**

**Power: 5600W**

**Screen  
Size : 7 Inches Touch  
Screen**

**Size : 790 \* 700 \* 520 mm**

**Voltage  
Frequency : 220V/50~60Hz**



MYTH DUAL GROUP ESPRESSO MACHINE

## Legend Evolution Forging Myth

PID | 7.0 INCH SCREEN | SATURATED GROUP HEAD



**LAJETINA**<sup>®</sup>  
拉迪天纳



ADJUSTABLE PRE-  
INFUSION TIME



PID TEMPERATURE  
CONTROL



SATURATED GROUP  
HEAD

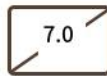

7.0-INCH  
TOUCHSCREEN



COLD & HOT HYBRID  
TECHNOLOGY

8.8

CAFFEE EXTRACTION IS  
MONITORED IN REAL  
TIME



## Paddle extraction switch - Bring a new operating experience



**Single cup  
quantitative**

**Quantitative extraction**

**Turn left**



**Double cup  
quantitative**

**Quantitative extraction**

**Turn right**

Legend Evolution Forging Myth

  
SATURATED  
GROUP HEAD

  
PRE INFUSION  
FUNCTION

  
PID TEMPERATURE  
CONTROL TECHNOLOGY



# Saturated Group Head

## Multiple Boilers T2 Heating System

**7L** Stainless steel Heat Exchange Boiler

**1.2L** Saturation Group head\*2

Endurance worry free, Ensure stable quality of coffee extraction



## One-Touch backflush Cleaning Function



Extraction channel inside the coffee  
machine is clean as new

Reverse the direction of water flow, allowing clear water to flow backwards and wash the extraction channel and filter screen inside the coffee machine, Thoroughly remove residual coffee grounds and oil impurities from the pipeline to prevent scale buildup from affecting coffee flavor or causing blockages, ensuring long-term smooth operation of the machine. (Should be used in conjunction with coffee machine specific cleaning powder)





## Hot-Cold Water Mixing Technology

**Hot-Cold Water Mixing Technology**  
**Adjustable Cold Water Ratio**  
**Keep The Water Stable Flow**



# Coffee Machine Pre Infusion System

Commercial grade pre-infusion function, support pre-infusion adjustable time to 0.1 second to make coffee powder fully soaked to exhaust the hydrophobic gas, so that the gouache powder can be more fully contacted and extracted during the subsequent brewing process. The coffee grounds are fermented in a vacuum environment after a few seconds of short water pouring in thus breeding a more fragrant aroma and rich taste.

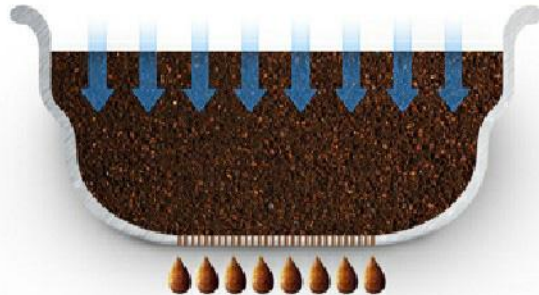

Pre Infusion effect



Non Pre Infusion effect

## PID温度加热控制技术

PID TEMPERATURE HEATING CONTROL TECHNOLOGY

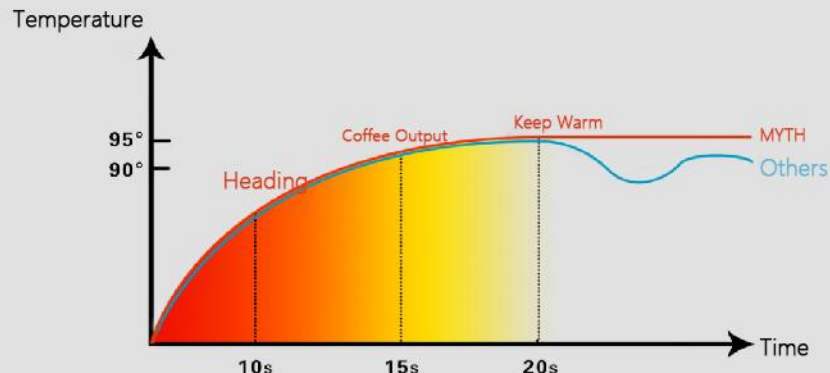

- By calculating the temperature of the boiler and automatically adjusting the heating frequency, the extraction temperature of the brewing head is kept constant
- Group head should be empty and drained for more than 10 minutes, and the water temperature should not be lower than 90 °C

LAJETINA®

拉迪天纳

## PID temperature Control technology

PID temperature control technology is a computational program, By calculating the temperature changes of the boiler Automatically adjust the heating frequency of the coffee machine.

Compared to traditional coffee machines, It can reduce unnecessary heating time and save energy consumption, The extraction temperature can also be kept stable.

LAJETINA

## High-value Appearance Design

High-value appearance design

*Perfect Combination of Art and Technology*

*Store's Style Has Been Significantly Enhanced*

*-Support Customization*



# Usage scenario





大正咖啡集团  
DAZHENG COFFEE GROUP



COFFEE & TEA  
SYSTEM SERVICE  
PROVIDER

# THANKS

✉ [sales@coffeedazheng.com](mailto:sales@coffeedazheng.com)

☎ +86 18011762132

🌐 [www.coffeedazheng.com](http://www.coffeedazheng.com)